

DSR-350N

APILADOR MANUAL PARA MANEJO DE TAMBORES

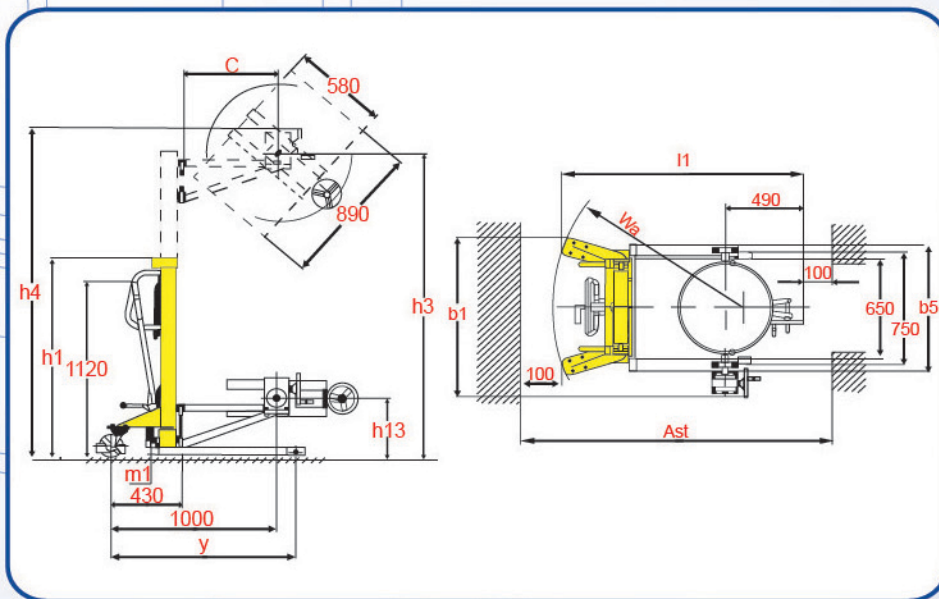

¡ROTE TAMBORES CON TOTAL SEGURIDAD!



MODELO	DSR-350N	
Capacidad	kg	350
Centro de carga	(c) mm	570
Largo de base de soporte	(y) mm	1115
Altura con mástil contraído	mm	1490
Altura máxima de elevación	(h3) mm	2385
Altura del mástil extendido	(h4) mm	2640
Altura mínima de aditamento	(h1)3 mm	385
Largo total con aditamento	(l1) mm	1520
Ancho total	(b1) mm	1050
Ancho total de patas	(b5) mm	840
Claro a piso	(m1) mm	22
Radio de giro	Wa mm	1200
Peso neto	kg	131

DISTRIBUIDOR AUTORIZADO

