

HAND PALLET TRUCK

HPT28U

5,500 lbs

Toyota's rugged yet lightweight hand pallet truck, designed to meet and exceed demands of your toughest workplace.



COMMITMENT

- Each hand pallet truck is backed by unequalled support and service to deliver the quality and reliability you need for all your material handling applications.

WARRANTY

- Toyota hand pallet trucks come with a 2-year warranty on the pump and frame.

TOYOTA QUALITY

OPERABILITY/PERFORMANCE

- A 3" low profile construction, 180° steering arc, low rolling resistance, and single load wheels with entry/exit rollers all help offer excellent maneuverability for maximum performance and productivity.

EASE OF SERVICE

- A stainless steel lowering valve, 10 grease fittings, an adjustable valve rod and heavy duty ball-type thrust bearing have been included to provide maximum uptime and years of service.

ERGONOMICS

- The large diameter hand grip with curvilinear design and three position handle with neutral position all help reduce operator fatigue and enhance operator comfort for improved productivity.

RELIABILITY/DURABILITY

- Toyota lift trucks are known for their quality, dependability and stand-out productivity. Toyota's hand pallet truck, with c-channeled design roll-formed steel for maximum frame strength, is no exception.

 **TOYOTA**
INDUSTRIAL EQUIPMENT



ERGONOMIC HANDLE

- Large diameter hand grip with curvilinear design
- Three position handle with neutral position
- Fingertip control of all functions
- Strong handle return spring
- Solid metal control lever with rubber coating



MANEUVERABLE DESIGN

- 3" Low profile construction
- 180° Steering arc
- Easy load handling in tight areas
- Precise, light-weight steering control
- Quiet operation



RELIABLE HYDRAULIC PUMP

- One piece, leak proof cast iron pump body
- heavy-duty ball-type thrust bearing for easy steering
- Variable speed lowering
- 1-3/8" diameter lift cylinder
- Strong, adjustable valve rod
- Stainless steel lowering valve



DURABLE FRAME

- High tensile strength steel frame
- Single-piece, C-channel design
- roll-formed steel forks for maximum strength
- 10 grease points for ease of service
- Adjustable push-rods
- Durable powder coat paint finish



HEAVY-DUTY WHEELS

- Solid nylon load wheels & steer wheels
- Single load wheels with entry/exit rollers
- Low rolling resistance
- Spoked steer wheel hub design for better shock resistance

Details of specifications and equipment are based on information available at the time of printing and may change without notice.

For more information or the nearest Toyota dealer, call **1-800-226-0009** or visit www.toyotaforklift.com.

HPT28U - SPECIFICATIONS

Unit: inches

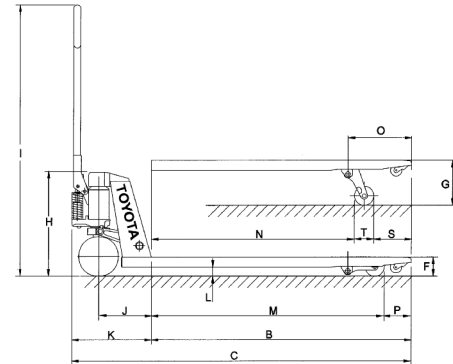
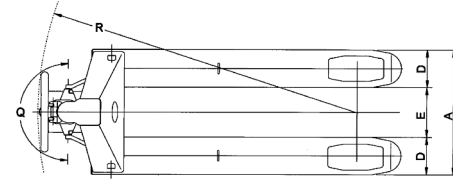

Capacity	5,500 lbs
Load Center	24"
Truck Weight	167 lbs
(A) Overall Width	27"
(B) Fork Length	48"
(C) Overall Length	63"
(D) Fork Width	6.25"
(E) Width Between Forks	14.5"
(F) Lowered Height	3"
(G) Raised Height	7.75"
(H) Chassis Height (Lowered)	17.63"
(I) Handle Height	48"
(J) A-Frame to Steer Wheel Center	9.1"
(K) Front-End Length	14.63"
(L) Underclearance (Lowered)	1.2"
(M) A-Frame to Load Wheel (Lowered)	43.5"
(N) A-Frame to Load Wheel (Raised)	41.9"
(O) Fork Tip to Assembly Pivot Point	10.6"
(P) Fork Tip to Load Wheel (Lowered)	4.5"
(Q) Steering Arc	180°
(R) Turning Radius	57.1"
(S) Fork Tip to Load Wheel (Raised)	6.1"
(T) Load Wheel Diameter	2.95"

CONTACT YOUR LOCAL DEALER FOR COMPLETE LIST OF OPTIONS & SPECIFICATIONS.

OPTIONS

- Various fork widths (20.5" & 27")
- Various fork lengths (36", 42" & 48")
- White Nylon, Polyurethane or Steel load and steer wheels
- 48" load backrest
- Quick-lift pump model
- Parking brake
- Power-assist model (5,000 lbs capacity)
- Stainless steel model (4,400 lb capacity)

00722-98160-708 11/13
Litho in U.S.A (1M)

©2013 Toyota Material Handling, U.S.A, Inc.